

pHiKEC™, pHiKUP™, and sensorlogger™ are trademarks of phionics inc. The pHiKEC™ connector system and the pHiKUP™ array system are covered by U.S. Patent Nos. 6,331,117, 6,612,848, 6,824,394, 6,834,560, 6,993,998, and various patents pending. Copyright phionics 2006.

dual output, 4-20 ma, water quality transmitters

conductivity, ORP (redox), pH, dissolved oxygen, and specific ion

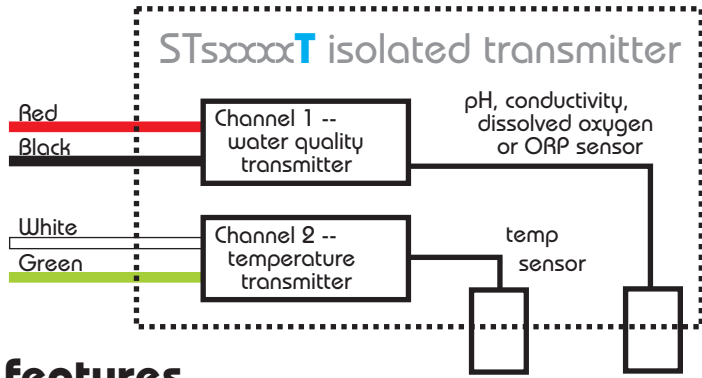

features

- isolated 4-20 ma outputs -- operate down to 7 volts
- independent temperature output (0 to 50 °C)
- available with conductivity, dissolved oxygen, ORP or pH
- 316SS (titanium optional) and PVDF (Kynar) construction
- patented pHiKEC™ connector system -- allows for 'two-turn' cable and sensor assembly
- 'true' 2-wire operation
- automatic temperature compensation
- auto-polarity correction
- small, 3/4" (19mm) diameter -- ideal for wells
- includes replaceable 10 meter cable (33 feet) -- polyurethane jacketed, Kevlar reinforced, and, water-blocked
- patented pHiKUP™ retaining system -- prevents blow-outs in in-line, insertion applications -- also allows for flexible, multi-parameter configuration

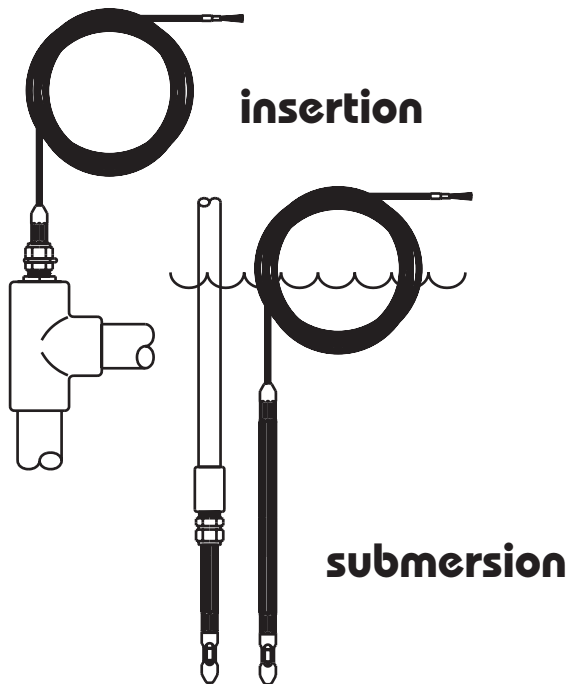

submersible cable assembly can be replaced or swapped with only '2-turns'

patented pHiKEC™ connection system allows for fast configuration or service of sensor

3/4" diameter (19mm) 316 SS housing (titanium optional)

isolated differential amplifier input (reduces noise)

patented pHiKUP™ system -- allows for easy multiparameter configuration

field replaceable, sensor cartridges (only '2-turns')

protective PVDF guard

